



STEALTH Sensor with special 200° detection pattern to provide wide coverage side to side. Excellent for building perimeter protection. Lens masks allow customization of detection zone.

Color: Bronze

Weight: 1.0 lbs

<b>Project:</b>	<b>Type:</b>
<b>Prepared By:</b>	<b>Date:</b>

**Technical Specifications**

**Compliance**

**UL Listed:**

Raintight Photoelectric Switch

**Electrical**

**Switching Capacity:**

8 amps

**Voltage:**

277V  
300W LED

**Surge Protection:**

I.E.C specs

**Sensor Specifications**

**Detection Pattern:**

50' x 200°

**Time Adjustment:**

5 seconds to 12 minutes

**Power Consumption:**

1 watt

**Other**

**Warranty:**

10-year sensor warranty

**Buy American Act Compliance:**

RAB values USA manufacturing! Upon request, RAB may be able to manufacture this product to be compliant with the Buy American Act (BAA). Please contact customer service to request a quote for the product to be made BAA compliant.

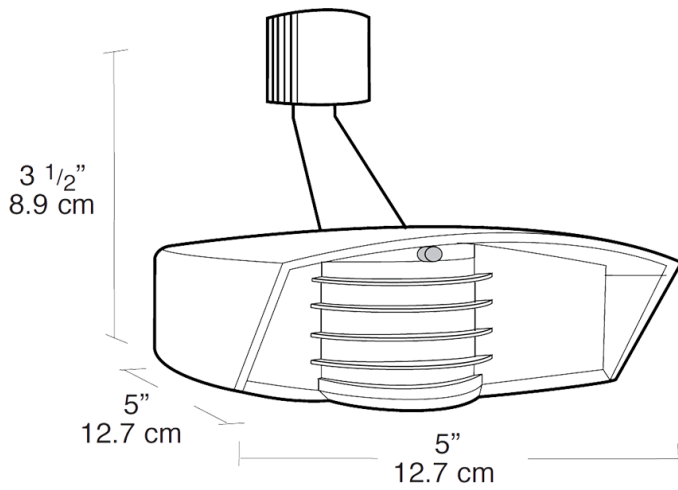
**Dimensions****Features**

- Compatible with LED lamps
- Temperature compensation
- Radio frequency immunity
- 6000 volt surge protection
- LED detection & "on guard" indicator
- Color matched vandal resistant lens and grill
- Protected manual override with auto reset
- Can be wired in parallel