



Same small package. Bigger output. Replaces 50W MR16 Floodlight.

Color: Black

Weight: 1.6 lbs

Project:

Type:

Prepared By:

Date:

Driver Info

Type	Constant Current
120V	0.14A
208V	0.09A
240V	0.08A
277V	N/A
Input Watts	7.2W

LED Info

Watts	8W
Color Temp	4000K (Neutral)
Color Accuracy	82 CRI
L70 Lifespan	100,000 Hours
Lumens	469 lm
Efficacy	65.1 lm/W

Technical Specifications

Compliance

UL Listed:

Suitable for wet locations. Suitable for ground mounting.

IESNA LM-79 & lm-80 Testing:

RAB LED luminaires and LED components have been tested by an independent laboratory in accordance with IESNA lm-79 and lm-80

LED Characteristics

LED:

High-output, long-life LED

Color Consistency:

4-step MacAdam Ellipse binning to achieve consistent fixture-to-fixture color

Color Stability:

LED color temperature is warranted to shift no more than 200K in color temperature over a 5-year period

Color Uniformity:

RAB's range of Correlated Color Temperature follows the guidelines of the American National Standard for (SSL) Products, ANSI C78.377-2017.

Optical

Spot Lens:

Optional spot lens enables a tool-less conversion to a NEMA Type 3H x 3V. Great for accent lighting or grazing buildings for an artistic touch. [Spot reflector kit available here.](#)

Narrow Spot Lens:

Optional narrow spot lens enables a tool-less conversion to a NEMA Type 3H x 3V. Great for accent lighting or grazing buildings for an artistic touch. [Narrow spot reflector kit available here.](#)

Construction

Cold Weather Starting:

The minimum starting temperature is -40°C (-40°F)

Ambient Temperature:

Suitable for use in up to 40°C (104°F)

Thermal Management:

Optimized using computational fluid dynamics software to ensure long LED and driver lifespan

Housing:

Precision die-cast aluminum, lens frame and mounting arm

Lens:

Microprismatic diffuser produces a smooth distribution and low glare

Gaskets:

High-temperature silicone

Finish:

Our environmentally friendly polyester powder coatings are formulated for high-durability and long-lasting color, and contains no VOC or toxic heavy metals

Green Technology:

Mercury and UV free. RoHS-compliant components.

Other

Warranty:

RAB warrants that our LED products will be free from defects in materials and workmanship for a period of five (5) years from the date of delivery to the end user, including coverage of light output, color stability, driver performance and fixture finish. RAB's warranty is subject to all terms and conditions found at rablighting.com/warranty.

Patents:

The design of the LFLED is protected by Taiwan Patent 01510966 and pending patents in US, Canada, China, and Mexico

Technical Specifications (continued)

Buy American Act Compliance:

RAB values USA manufacturing! Upon request, RAB may be able to manufacture this product to be compliant with the Buy American Act (BAA). Please contact customer service to request a quote for the product to be made BAA compliant.

Electrical

Driver:

Constant Current, Class 2, 50/60 Hz, 100-240VAC:
0.20Amps

Dimensions

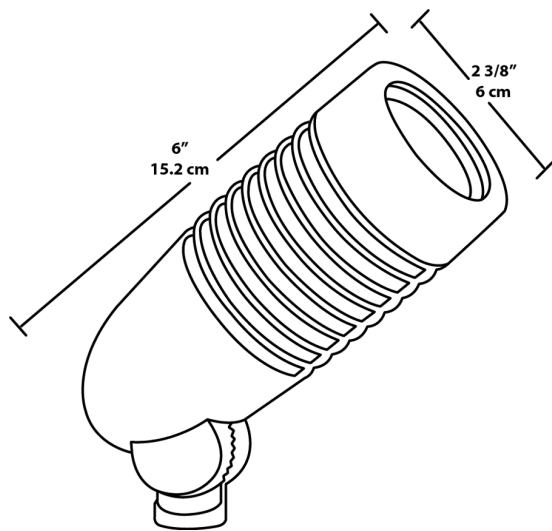

Features

- Microprismatic diffuser produces a smooth distribution and low glare
- 4H x 4V NEMA beam spread
- Optional spot and narrow spot hood reflectors available
- Runs cool; prevents burning foliage or fingers
- 5-Year, No-Compromise Warranty

Ordering Matrix

Family	Wattage	Color Temp	Finish
LFLED	8	N	B
	8 = 8W	Blank = 5000K Cool N = 4000K Neutral Y = 3000K Warm	A = Bronze W = White B = Black VG = Verde Green