



Color: Gray

Weight: 22.6 lbs

Project:	Type:
Prepared By:	Date:

Driver Info		LED Info	
Type	Constant Current	Watts	150W
120V	1.29A	Color Temp	5000K
208V	0.72A	Color Accuracy	78 CRI
240V	0.63A	L70 Lifespan	100,000 Hours
277V	0.56A	Lumens	18,745 lm
Input Watts	155.2W	Efficacy	120.8

Technical Specifications

Hazardous Location Classifications

Class I Division 2 (Groups A, B, C, D):

Class I: A hazardous location in which flammable gases or vapors may be present in the air in sufficient quantities to be explosive or ignitable, such as petroleum refineries, aircraft hangars, dry cleaning plants, utility gas plants or storage areas for liquified petroleum or natural gas, and spray finishing areas.

Division 2: Abnormal condition, where ignitable concentrations of flammable gases, vapors or liquids are not like to exist under normal operating conditions, for example: Closed storage drums containing flammable liquids in an inside storage room would not normal allow the hazardous vapors to escape into the atmosphere. But if one of the containers is leaking, you've got an abnormal condition.

Group A - The only substance in group A is acetylene because it is a gas with extremely high explosion pressures.

Group B - This group includes hydrogen and other materials with similar characteristics.

Group C & D - The most usual Class 1 groups. They comprise the greatest percentage of all Class I hazardous locations. Found in Group C is ethylene. Found in Group D are many of the most common flammable substances such as butane, gasoline, natural gas and propane.

Class II Division 1 (Groups E, F, G):

Class II: Combustible dust may be present
Division 1: Ignitable concentrations of hazards exist under normal operation conditions and/or where the hazard is caused by frequent maintenance or repair work or frequent equipment failure

E: Combustible metal dusts: aluminum, commercial alloys and magnesium

F: Combustible carbonaceous dusts: carbon black, charcoal, coal and coke dusts

G: Other combustible dusts: Chemicals, flour, grain, plastic and wood

Class II Division 2 (Groups F, G):

Class II: Combustible dust may be present
Division 2: Ignitable concentrations of hazards exist under abnormal operation conditions

F: Combustible carbonaceous dusts: carbon black, charcoal, coal and coke dusts

G: Other combustible dusts: Chemicals, flour, grain, plastic and wood

Class III:

Class III: Easily ignitable fibers or flyings may be present

UL 844:

Electric lighting fixtures for use in hazardous (classified) locations

UL 1598:

Electric lighting fixtures for use in non-hazardous locations

Compliance

UL Listed:

Suitable for wet locations

IESNA LM-79 & LM-80 Testing:

RAB LED luminaires and LED components have been tested by an independent laboratory in accordance with IESNA LM-79 and LM-80.

IP Rating:

Ingress protection rating of IP66 for dust and water

DLC Listed:

This product is on the Design Lights Consortium (DLC) Qualified Products List and is eligible for rebates from DLC Member Utilities. Designed to meet DLC 5.1 requirements.
DLC Product Code: S-P0G4Y3

Electrical

Driver:

Constant Current, Class 2, 50/60 Hz, 120V-277V, 120V: 1.29A, 208V: 0.72A, 240V: 0.63A, 277V: 0.56A

Technical Specifications (continued)

Dimming Driver:

Driver includes dimming control wiring for 0-10V dimming systems. Requires separate 0-10V DC dimming circuit. Dims down to 10%.

THD:

5.91% at 120V, 8.85% at 277V

Power Factor:

99.8% at 120V, 97.5% at 277V

Surge Protection:

L-N:4KV
L/N-FG:6KV

Battery Backup:

Battery backup will operate the LED Lamp for 90 minutes if power fails. Wired for 120V-277V. Illuminated push to test switch available to test battery backup functionality.

Construction

Cold Weather Starting:

The minimum starting temperature is $T_a = 0^{\circ}\text{C}$ (32 $^{\circ}\text{F}$)

Maximum Ambient Temperature:

Suitable for use in up to $T_a = 40^{\circ}\text{C}$ (104 $^{\circ}\text{F}$)

Housing:

Die-cast aluminum

Mounting:

Surface and pendant mount. Remove yoke for pendant mount.

Lens/Globes:

Frosted flat glass lens

Gaskets:

High-temperature silicone

Green Technology:

Mercury and UV free. RoHS-compliant components.

Finish:

Formulated for high durability and long-lasting color

LED Characteristics

LEDs:

Long-life, high-efficacy, surface-mount LEDs

Color Uniformity:

RAB's range of Correlated Color Temperature follows the guidelines of the American National Standard for Specifications for the Chromaticity of Solid State Lighting (SSL) Products, ANSI C78.377-2017.

Color Consistency:

7-step MacAdam Ellipse binning to achieve consistent fixture-to-fixture color

Performance

Lifespan:

100,000-Hour LED lifespan based on IES LM-80 results and TM-21 calculations

Optical

BUG Rating:

B2 U0 G1

Other

Warranty:

RAB warrants that our LED products will be free from defects in materials and workmanship for a period of five (5) years from the date of delivery to the end user, including coverage of light output, color stability, driver performance and fixture finish. RAB's warranty is subject to all terms and conditions found at rablighting.com/warranty.

Buy American Act Compliance:

RAB values USA manufacturing! Upon request, RAB may be able to manufacture this product to be compliant with the Buy American Act (BAA). Please contact customer service to request a quote for the product to be made BAA compliant.

Dimensions

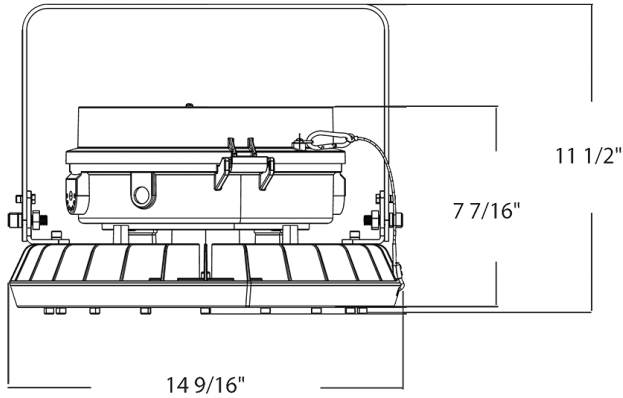

Features

- Class 1, Division 2, Groups A, B, C, D
- Class II Division 1 (Groups E, F, G)
- Class II Division 2 (Groups F, G)
- Class III
- IP66 Rating protects against dust & water ingress
- 100,000-Hour LED lifespan
- 5-Year, no-compromise warranty

Ordering Matrix

Family	Wattage	Color Temp	Mount	Finish	Lens/Globe	Voltage	Options
HAZBAYLED	150				FF		/E
	100 = 100W 150 = 150W 200 = 200W 300 = 300W	Blank = 5000K	Blank = Surface/Pendant	Blank = Gray	CF = Clear Flat Lens FF = Frosted Flat Lens	Blank = 120-277V, 0-10V Dimming /480 = 480V ¹	Blank = No Option /E = Battery Backup ²

¹ Not available in the 100W

² Battery Backup not available with 480V