

Color: White

Weight: 3.6 lbs

Project:

Type:

Prepared By:

Date:

Driver Info

Type	Constant Current
120V	0.17A
208V	0.10A
240V	0.09A
277V	0.08A
Input Watts	5.7-21.3W

LED Info

Watts	20W
Color Temp	3000K/3500K/4000K
Color Accuracy	94-96 CRI
L70 Lifespan	50,000 Hours
Lumens	738-2,941 lm
Efficacy	127.2-143.5 lm/W

Technical Specifications**Field Adjustability****Field Adjustable:**

Field Adjustable Light Output:
20W/14W/12W/10W/5W (factory default 20W)
Color Temperature Selectable:
3000K, 3500K and 4000K (factory default 4000K)

Compliance**UL Listed:**

Suitable for damp locations

DLC Listed:

This product is listed by Design Lights Consortium (DLC) as an ultra-efficient premium product that qualifies for the highest tier of rebates from DLC Member Utilities. Designed to meet DLC 5.1 requirements.

DLC Product Code: S-0NGT4K

Electrical**Driver:**

Constant Current, Class 2, 120-277V, 50/60 Hz:
20W: 120V: 0.17A, 208V: 0.10A, 240V: 0.09A, 277V: 0.08A
14W: 120V: 0.12A, 208V: 0.07A, 240V: 0.06A, 277V: 0.05A
12W: 120V: 0.10A, 208V: 0.06A, 240V: 0.05A, 277V: 0.05A
10W: 120V: 0.09A, 208V: 0.06A, 240V: 0.05A, 277V: 0.04A
5W: 120V: 0.05A, 208V: 0.03A, 240V: 0.02A, 277V: 0.02A

Dimming Driver:

Driver includes dimming control wiring for 0-10V dimming systems. Requires separate 0-10V DC dimming circuit. Dims down to 10%.

THD:

4.09% at 120V, 7.91% at 277V

Power Factor:

99.6% at 120V, 93.3% at 277V

Surge Protection:

2kV

Status Indicator:

The status indicator light is located around the circumference of the top of the Controller.

Solid Green - Nano is paired to the Lightcloud Blue app
Flashing Red - Nano has been restored to default factory settings

Device Identification Button:

Located at the top of the controller under the Lightcloud logo.
Once the Controller has been provisioned to the Lightcloud Blue mobile app this button offers the following functionality:
Press once to rapid identify this device in the Lightcloud Blue mobile app
Press twice to toggle circuit on and off
Press twice and hold to set dim level
Press and hold for 10s to reset the device to factory settings and into pairing mode

Sensor Connection Type:

RJ09

Max Mounting Height:

8 ft to 12 ft

Detection Range:

20 ft diameter at 9 ft mounting height

LED Characteristics**LEDs:**

Long-life, high-efficacy, surface-mount LEDs

Color Uniformity:

RAB's range of Correlated Color Temperature follows the guidelines of the American National Standard for Specifications for the Chromaticity of Solid State Lighting (SSL) Products, ANSI C78.377-2017.

Technical Specifications (continued)

Performance

Lifespan:

50,000-Hour LED lifespan based on IES LM-80 results and TM-21 calculations

Performance Data:

[Click here for the BOA2 performance data](#)

Wattage Equivalency:

20W: Replaces up to (1) F32T8 or (3) F17T8

14W: Replaces up to (1) F32T8 or (2) F17T8

12W: Replaces up to (1) F32T8 or (2) F17T8

10W: Replaces up to (1) F32T8 or (1) F17T8

5W: Replaces up to (1) F32T8 or (1) F17T8

Construction

Cold Weather Starting:

The minimum starting temperature is -20°C (-4°F)

Maximum Ambient Temperature:

Suitable for use in up to 40°C (104°F)

Housing:

Aluminum

Mounting:

Trimless design for a clean and seamless appearance

Lens:

Polycarbonate reflective louvers lens

Reflector:

Polyethylene Terephthalate (PET)

Finish:

Formulated for high durability and long-lasting color

Green Technology:

Mercury and UV free. RoHS-compliant components.

Lightcloud

Lightcloud Blue:

Lightcloud Blue is a Bluetooth mesh wireless lighting control system that allows you to control RAB's various compatible devices. With RAB's patent-pending Rapid Provisioning technology, devices can be quickly and easily commissioned for residential and large commercial applications using the Lightcloud Blue mobile app. Each device in a system can communicate with any other device, eliminating the need for a Gateway or Hub and maximizing the control system's reach.

DLC system - N1XMLOEATBA

[Learn more at www.lightcloud.com](http://www.lightcloud.com)

Gateway Required:

No

Communication Protocol:

Bluetooth Mesh

Range:

Up to 60 feet between standard building materials.

Up to 200 feet clear line of sight.

Spacing Criteria:

Lightcloud Blue devices should be placed within the specified range to communicate within the Bluetooth Mesh network.

Factory Reset:

Method 1: Delete from App

Open the app and access the device settings for the paired device. Be sure that the device is online and select 'Delete'. The device will flash on/off 5 times and return to full brightness.

Method 2: Manual

Locate the device identification button at the top of the Controller under the Lightcloud logo. Press and hold this button for 10s or until the indicator light begins flashing red. If the Controller is attached to a fixture, the fixture will also flash on/off 5x.

Sensor Settings

Default Setting:

Uncommissioned State:

Sensor Status: Enabled

Motion Sensitivity: High

Brightness when triggered : 100%

Hold time: 1 minute

Standby to dim: 20%

Standby time: 1 minute

When vacant: Off

Commissioned State:

Sensor Status: Disabled, once enabled the following default are set.

Motion Sensitivity: High

Brightness when triggered: Last on status

Hold time: 20 minutes

When vacant: Off

Sensor Type:

Microwave (MVS)

Sensing Type:

Occupancy or Vacancy

Sensor Sensitivity:

Low/Medium/High

Occupied Actions:

On or On at a Dim Level

Vacant Options:

Off or On at a Dim Level

Occupancy Timeout:

1 minute to 240 minutes

Daylight Sensing:

The sensor will determine to trigger the light(s) on or not based on the daylight threshold level set in the Lightcloud Blue mobile app.

Daylight Threshold:

150 lux to 1500 lux

Other

Note:

All values are typical (tolerance +/- 10%)

5 Yr Limited Warranty:

The RAB 5-year, limited warranty covers light output, driver performance and paint finish. RAB's warranty is subject to all terms and conditions found at rablighting.com/warranty.

Technical Specifications (continued)

Buy American Act Compliance:

RAB values USA manufacturing! Upon request, RAB may be able to manufacture this product to be compliant with the Buy American Act (BAA). Please contact customer service to request a quote for the product to be made BAA compliant.

Dimensions

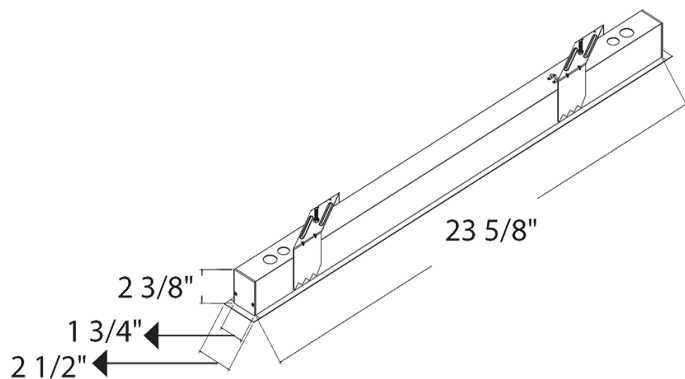

Features

- 50,000-Hour LED lifespan
- 0-10V dimming
- 5-Year, limited warranty

Ordering Matrix

Family	Size (Wattages)	Mount	Lens	Light Output	Color Temp	Voltage	Finish	Options
BOA	2 (20W/14W/12W/10W/5W) 4 = 4 ft (40W/28W/24W/20W/10W) 8 = 8 ft (80W/56W/48W/40W/20W)	R Recessed	L Blank = Flat L = Louvers	Blank = Downlight	Blank = 3000K/3500K/4000K CCT Adjustable	Blank = 120-277V, 0-10V Dimming	Blank = White	/LCBS/MVS Blank = No Option /MVS = Microwave Occupancy Sensor /PIR = Passive Infrared Occupancy Sensor /LCBS = Lightcloud® Blue Enabled w/ PIR Sensor /LCBS/MVS = Lightcloud® Blue Enabled w/ MVS Sensor /E = Battery Backup ² /MVS/E = Microwave Occupancy Sensor w/ Battery Backup ² /PIR/E = Passive Infrared Occupancy Sensor w/ Battery Backup ² /LCBS/E = Lightcloud® Blue Enabled w/ PIR Sensor and Battery Backup ² /LCBS/MVS/E = Lightcloud® Blue Enabled w/ MVS Sensor and Battery Backup ²

¹ Only available on 4 ft and 8 ft models only