

# Submittal Sheet



## D-65 Destratification Fan

### Specifications

Weight	Max RPM	Volts	Watts	Amps	Max CFM	dB(A)	Mounting height	Coverage area
15.62 lbs (7.1 kg)	2800	120	232	2.1	1082	54	up to 65 ft.	2000 ft.

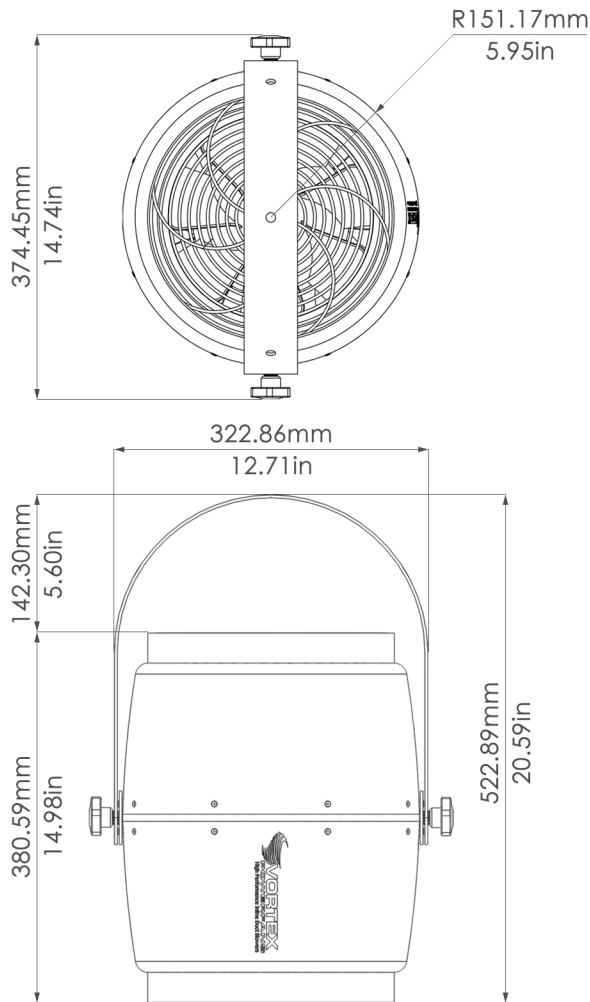

### DESTRATIFICATION FAN DESCRIPTION

The **Vortex D-65** creates uniform air temperatures from floor to ceiling for maximum thermal comfort and energy savings up to 35% in the heating season and up to 25% in the cooling season

### CERTIFICATION:

ETL certified for US and Canada Conforms to UL-507, CAN/CSA C22.2# 113

### HOUSING:

PC resin, UL94 V0 flame resistance rating

### MOTOR:

- Single phase, permanent split capacitor motor (variable speed with optional speed control)
- Motor is class F thermally protected
- **Operating temperature:** -13° F (-25° C) to 140° F (60° C)
- No lubrication required
- Bearings are sealed
- 6' cord and 3 prong plug provided for 120V

### IMPELLER:

Mixed flow for high volume, longer throw and low sound level

### STATOR:

3D shaped multi-vane stator significantly increases air throw to maximize performance

### MOUNTING HARDWARE:

2 x 10' Quick attached toggle steel cable + beam clamp, 12" treaded rod and metal self tapping anchor

### WARRANTY:

10 years (parts and workmanship)

**ACCESSORIES** (additional costs apply) **Speed Control** (coordinate w/ electrical requirement)

Item	Description	Qty
AVS-5 115	120V AC - 5A wall mounted speed control	
AVS-8 115	120V AC - 8A wall mounted speed control	

Project \_\_\_\_\_ Submitted by \_\_\_\_\_  
 Customer \_\_\_\_\_ Approved by \_\_\_\_\_  
 Location \_\_\_\_\_



2480 Boul. des Entreprises Terrebonne, Quebec J6X 4J8 CANADA  
 T: 450.477.1100 F: 514.313.5700 TF: 1.800.489.1301

WWW.ATMOSPHERE.COM

FEBRUARY 2020

Customer support : info@atmosphere.com  
 Sales inquiries : sales@atmosphere.com



## Panasonic

Panasonic is the exclusive distributor of Atmosphere products in the US

Panasonic IAQ Division For Order Information  
 Two Riverfront Plaza PHONE: 866-292-7299  
 Newark, NJ 07102 FAX: 888-553-0723  
 na.panasonic.com/us/iaq ventfans@us.panasonic.com

Design and specifications subject to change without notice.

\*Pending AMCA Certification\*