

Service Manual

Ventilating Fan
(North America Market)

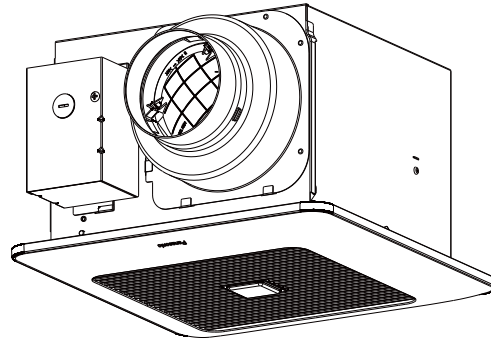

FV-0511VQC1

⚠ WARNING

This service information is designed for experienced repair technicians only and is not designed for use by the general public. It does not contain warnings or cautions to advise non-technical individuals of potential dangers in attempting to service a product. Products powered by electricity should be serviced or repaired only by experienced professional technicians. Any attempt to service or repair the product or products dealt with in this service information by anyone else could result in serious injury or death.

IMPORTANT SAFETY NOTICE

There are special components used in this equipment which are important for safety. These parts are marked by ⚠ in the Schematic Diagrams, Exploded Views and Replacement Parts List. It is essential that these critical parts should be replaced with manufacturer's specified parts to prevent shock, fire or other hazards. Do not modify the original design without the manufacturer's approval.

Please have a static electricity depletion process in place before handling these components..

Please use gloves when handling PCB parts during the repair process..

CONTENTS	PAGE
1.Specification-----	1
2.Parts Identification-----	2 ~ 4
3.Wiring Diagram-----	5
4.Parts List-----	6 ~ 7

1. Specification

Model No.	Air direction	Voltage (V)	Frequency (Hz)	Duct diameter (Inches)	Air volume at 0.1"WG (CFM)	Noise (sones)	Speed (rpm)	Power (W)	Weight lb. (kg)
FV-0511VQC1	Exhaust	120	60	4 or 6	50	< 0.3	756	4.1	9.5 (4.3)
					80	< 0.3	821	6.0	
					110	< 0.3	957	10.8	

HVI Certified performance based on HVI Procedures 915, 916, and 920.

Remark: We divide this model into Version A & Version B, because of different motor and Main PCB Section, please put attention with identification of parts when you request a service parts.

Parts for Version A

Motor

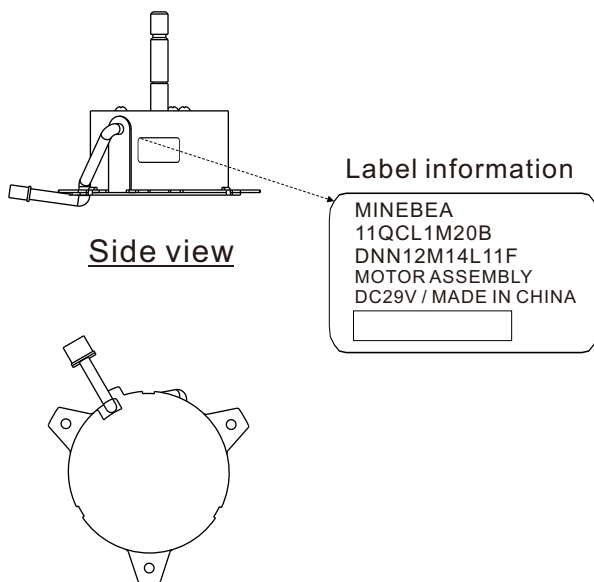

Main PCB Section

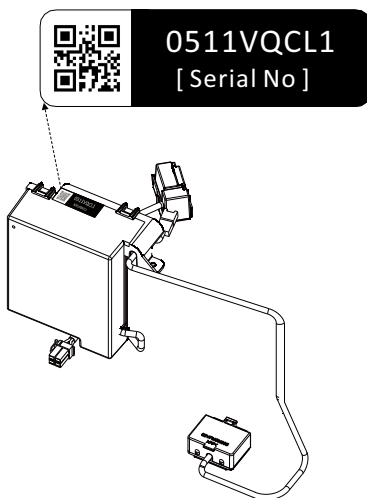

Parts for Version B

Motor

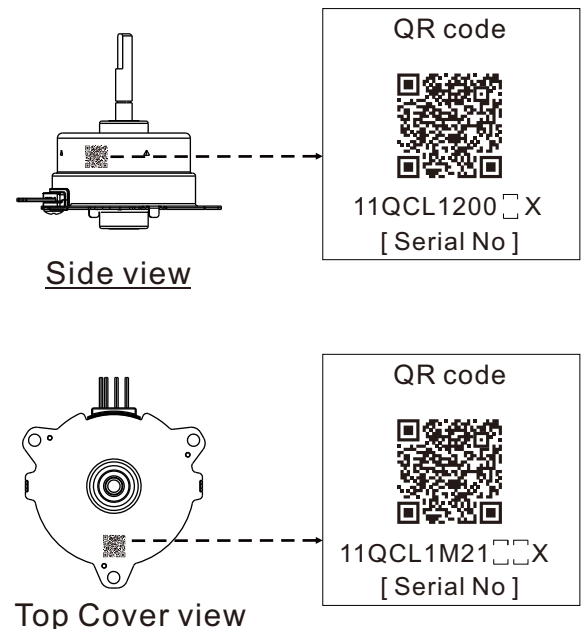

Main PCB Section

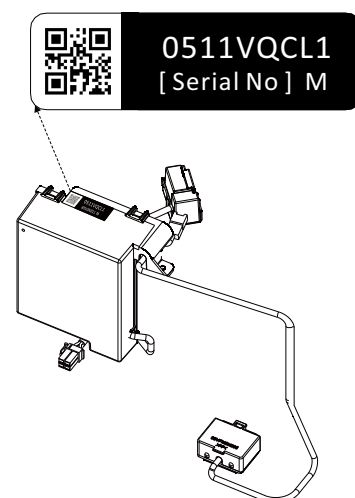

Motor	Main PCB	Judgment
Version A	Version A	(OK) Work
Version A	Version B	(NG) Do Not Work
Version B	Version B	(OK) Work
Version B	Version A	(NG) Do Not Work

2. Parts Identification

FV-0511VQC1

Main Body Section

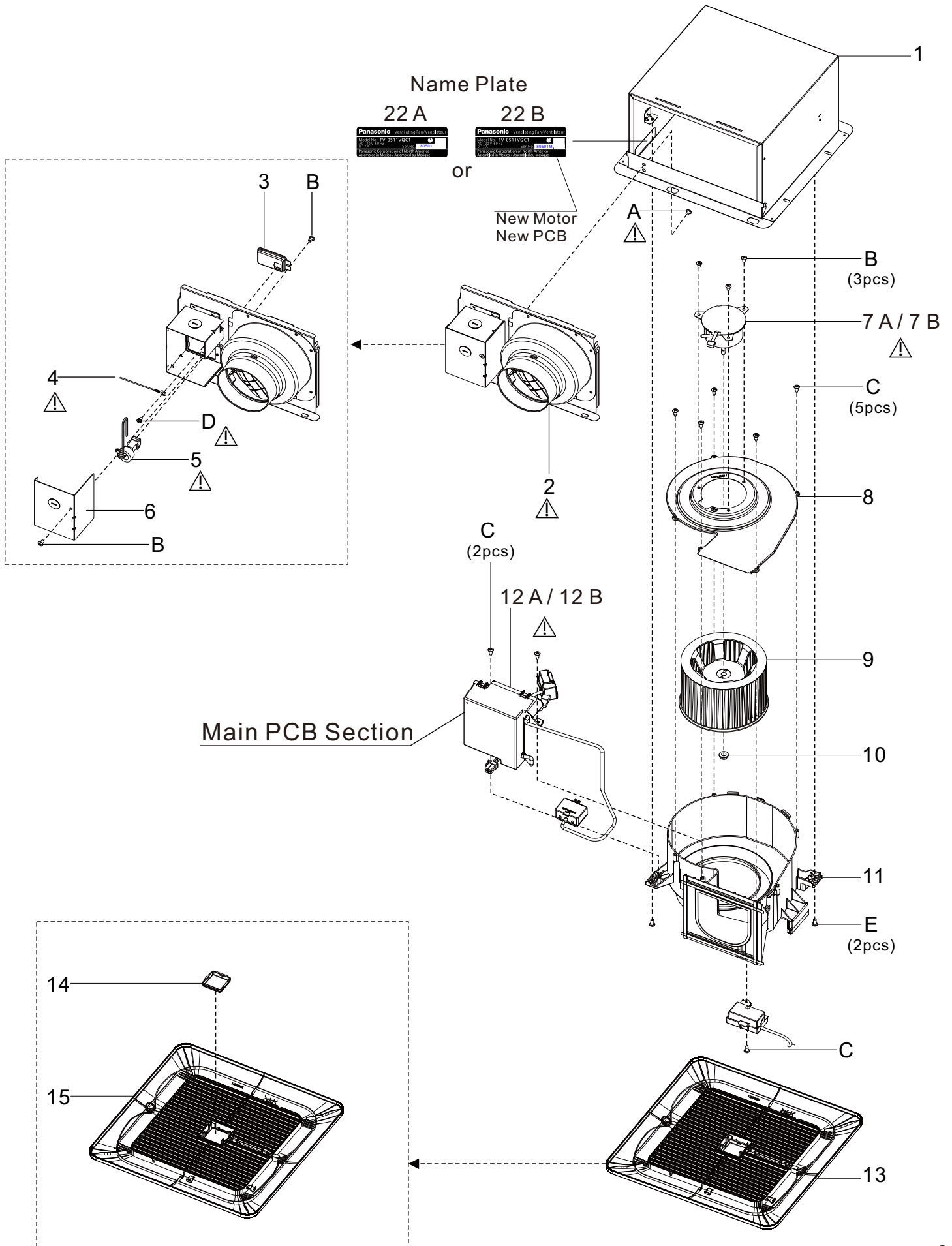

2. Parts Identification

FV-0511VQC1

Main PCB Section

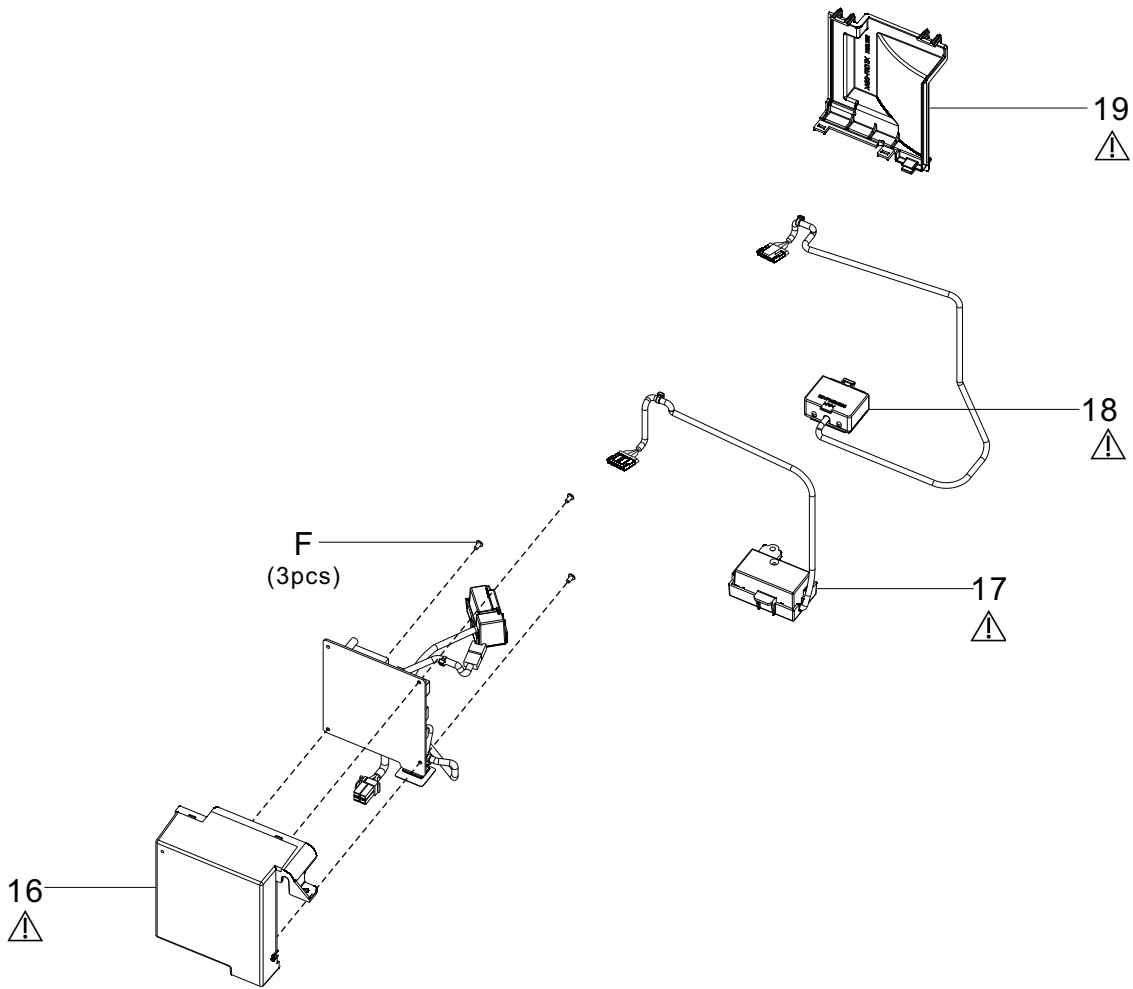

Main Label

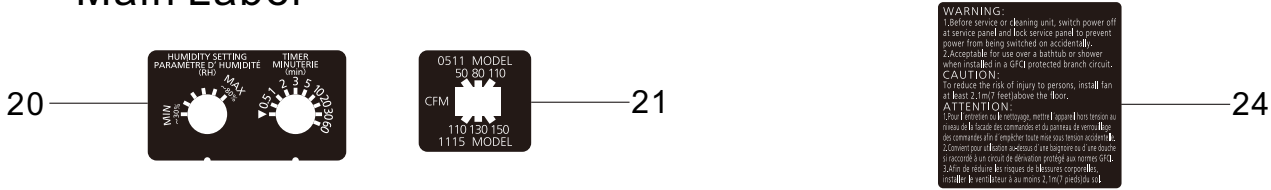

Part for Version A



8 Means Year: 2018
05 Means Month
01 Means Day

Part for Version B

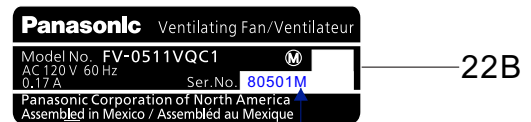

8 Means Year: 2018
05 Means Month
01 Means Day
M: In House MOTOR

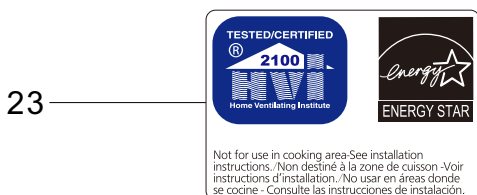

2. Parts Identification

FV-0511VQC1

Packing Section

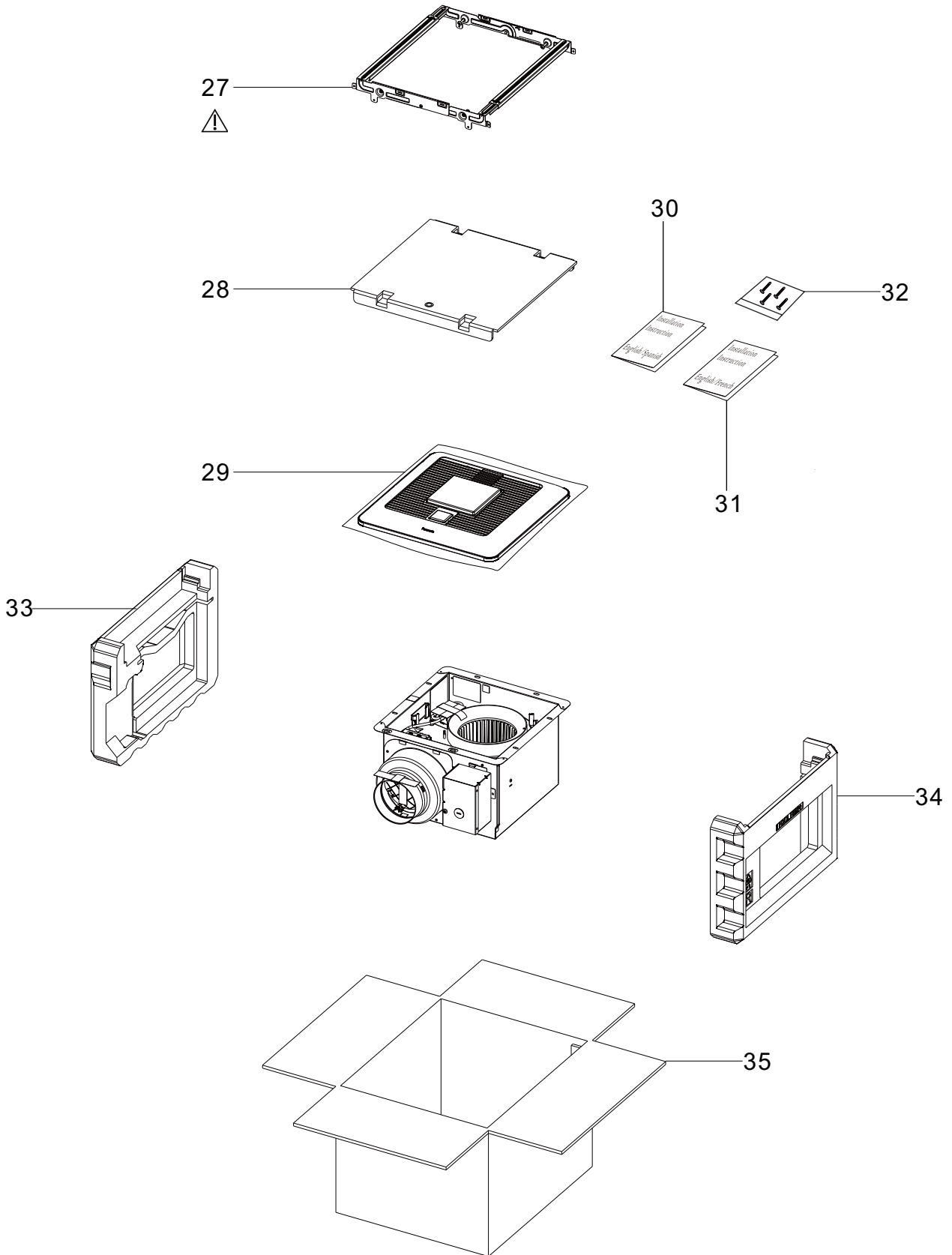

3. Wiring Diagram

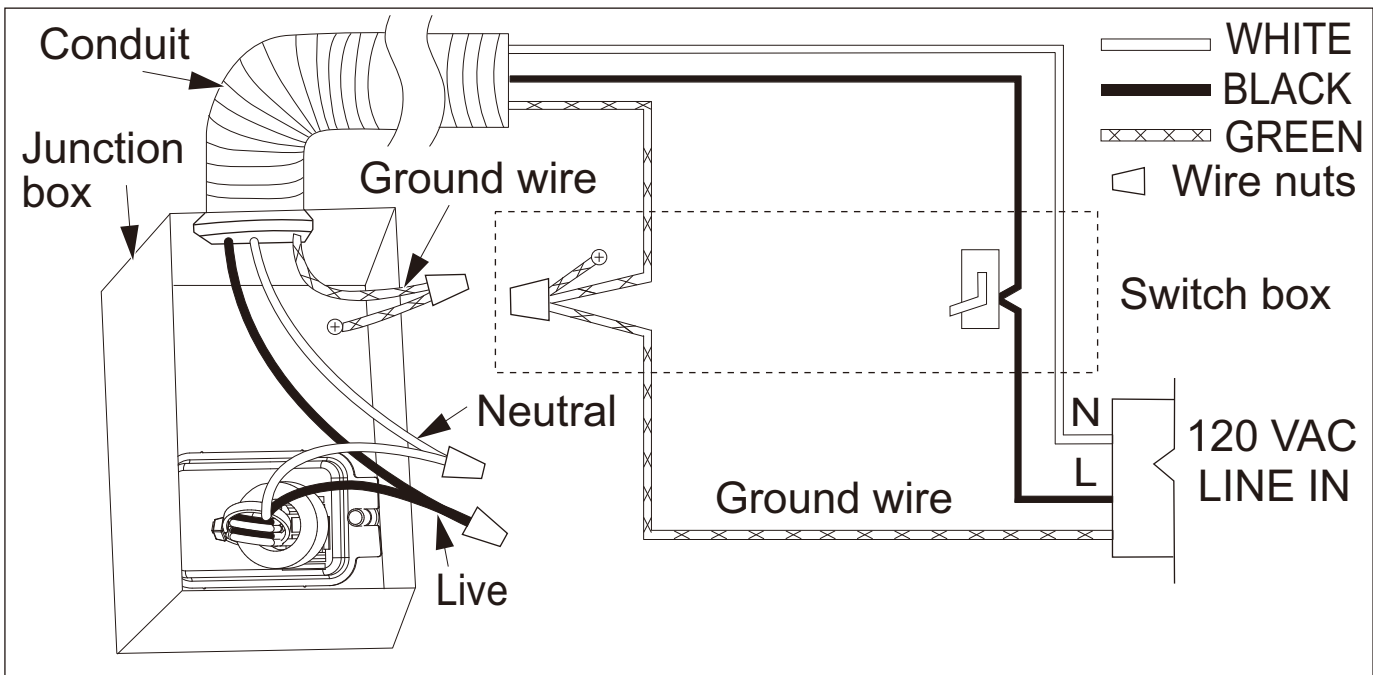
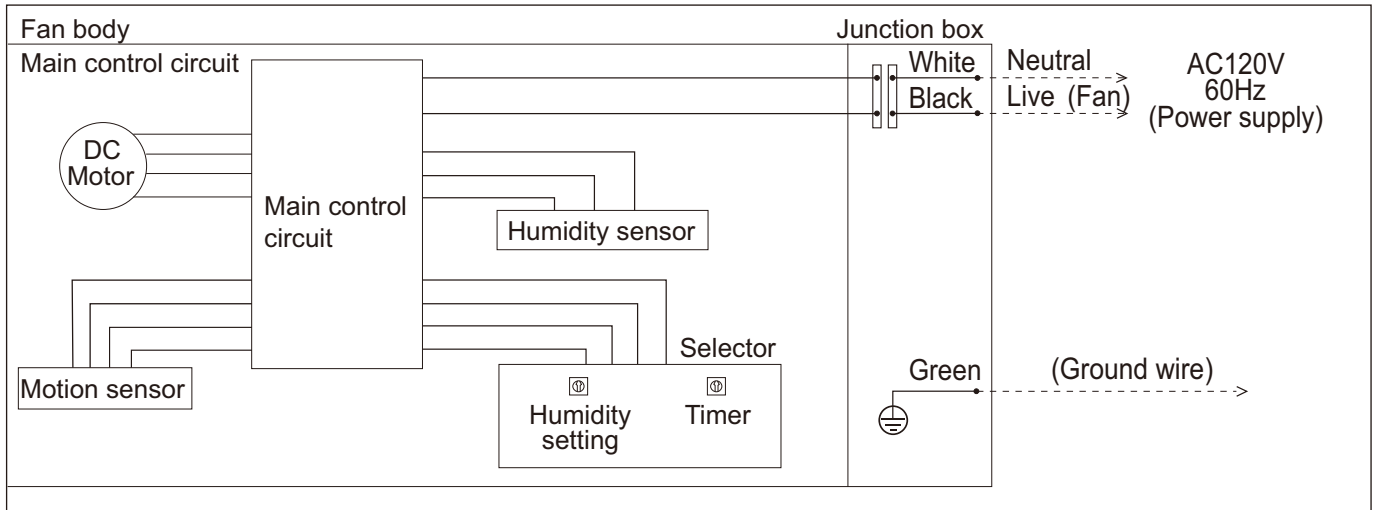

4. Parts List

FV-0511VQC1

Main Body Section

No.	Part No.	Part Name	Q'ty	Remark
1	FFV11QCL1900C	Frame Assembly	1	
2	FFV11VQC1910	Adapter Assembly	1	⚠
3	FFV08VKS3M915	Connector Plate	1	
4	FFV11QCL1331	Earth Lead Wire	1	⚠
5	FFV11QCL1301A	Connector Assy	1	⚠
6	FFV11QCL1912A	Junction Cover	1	
7A	FFV11QCL1M20A	Motor	1	Version A ⚠
7B	FFV11QCL1M21AX	Motor	1	Version B ⚠
8	FFV11QCL1904C	Motor Support	1	
9	FFV0400114S	Blade	1	
10	FFV7020021S	Nut	1	
11	FFV11QCL1906B	Casing	1	
12A	FFV0511VQCL1UPCB	Main PCB section	1	Version A ⚠
12B	FFV11VQCL1PCB	Main PCB section		Version B ⚠
13	FFV0511VQC1A	Grill Assembly	1	
14	FFV13KML3996C	Sensor Cover	1	
15	FFV0511VQC1S	Grill Section	1	
A	FFVXYM4-E8FJ	Screw (M4-8)	1	⚠
B	FFVXTT4-8FFJ	Screw (ST4-8)	5	
C	FFV7000089S	Screw (ST4-12)	8	
D	FFVXYM4DC8BN	Screw (M4-8)w/washer	1	⚠
E	FFV7000065S	Screw (M4-12)	2	

Main PCB Section

No.	Part No.	Part Name	Q'ty	Remark
16	FFV11QCL1991D	Main PCB Box	1	⚠
17	FFV11QCL1560	SW PCB Assy Set	1	⚠
18	FFV11QCL1540	Motion Sensor	1	⚠
19	FFV11QCL1992C	Main PCB Cover	1	⚠
F	FFVXTN3-8GFJ	Screw (M3-8)	3	

4. Parts List

FV-0511VQC1

Main Label

No.	Part No.	Part Name	Q'ty	Remark
20	FFV11QCL1011A	Switch Label	1	
21	FFV11QCL1012A	CFM Label	1	
22A	FFV11VQC1050	Name Plate	1	Version A
22B	FFV11VQC1050M	Name Plate	1	Version B
23	FFV0810011S	Caution Label 1	1	
24	FFV0810010S	Caution Label	1	
25	FFV6730045S	Warning Label	1	
26	FFV2260003S	Holograph Label	1	

Packing Section

No.	Part No.	Part Name	Q'ty	Remark
27	FFV11QCL1920	Hanger Assy	1	
28	FFV4710381S	Grill Pad Assy	1	
29	FFV4650016S	Poly Cover	1	
30	FFV15VQ10420B	Installation Inst	1	English / Spanish For USA Market
31	FFV15VQ10421	Installation Inst	1	English / French For CANADA Market
32	FFV11KSL1M031A	Accessory A	1	
33	FFV11QCL1891	Left Pad	1	
34	FFV11QCL1892	Right Pad	1	