



ARISTA

**ALC-DT-BT-WH Dual Tech In-Wall
Occ/Vac Sensor**



WARNINGS/SAFETY

⚠ WARNING

Risk of Fire or Electric Shock

- Disconnect power at the circuit breaker(s) or disconnect switch(es) before installing or servicing.
- Installation and/or wiring must be in accordance with national and local electrical code requirements.
- Only use copper conductors rated 105°C minimum.
- For INDOOR USE ONLY.

RATINGS¹

Operating Voltage - 120-277 VAC, 50/60 Hz

Operating Temperature - 0° - 55° C (32° - 131° F)

Dimensions - 2 3/4" H x 1 3/4" W x 1 2/3" D

¹Type 1 action, Operating Control, Pollution degree PD2, Impulse Voltage 4000V

COMPLIANCE

This device complies with part 15 of the FCC. Operation is subject to the following two conditions: (1) this device may not cause harmful interference, and (2) this device must accept any interference received, including interference that may cause undesired operation.

FCC NOTE: The manufacturer is not responsible for any radio or TV interference caused by unauthorized modifications to this equipment. Such modifications could void the user's authority to operate the equipment.

NOTE: This equipment has been tested and found to comply with the limits for a Class B digital device, pursuant to Part 15 of the FCC Rules. These limits are designed to provide reasonable protection against harmful interference in a residential installation. This equipment generates, uses and can radiate radio frequency energy and, if not installed and used in accordance with the instructions may cause harmful interference to radio communications. However, there is no guarantee that interference will not occur in a particular installation. If this equipment does cause harmful interference to radio or television reception, which can be determined by turning the equipment off and on, the user is encouraged to try to correct the interference by one or more of the following measures:

- Reorient or relocate the receiving antenna.
- Increase the separation between the equipment and receiver.
- Connect the equipment into an outlet on a circuit different from that to which the receiver is connected.
- Consult the dealer or an experienced radio/TV technician for help.

Important note: To comply with the FCC RF exposure compliance requirements, no change to the antenna or the device is permitted. Any change to the antenna or the device could result in the device exceeding the RF exposure requirements and void user's authority to operate the device.

This Class B digital apparatus complies with ICES-005 of Canada.

PRODUCT OVERVIEW

The ALC-DT-BT-WH is a Dual Technology (PIR and Ultrasonic) Sensor designed for use with the ARISTA Lighting Controls System by Intermatic and will control lighting based upon occupancy/vacancy. If the space is configured for Occupancy and movement is detected, the sensor informs the ARISTA controller(s) in the space and the lights will illuminate. The lights will turn off after the ARISTA controller(s) deem the space vacant and the timeout period completes. If the space is configured for Vacancy, the ARISTA controller(s) in the space will only react when they are manually activated. The lights will turn off after the ALC-DT-BT-WH deems the space vacant and the timeout period completes. The ALC-DT-BT-WH also utilizes a built-in switch that can be used as a manual override to the programmed ARISTA controller(s).

INSTALLATION

1. Turn off power to the controlling circuit.
2. Connect wires as shown in wiring diagram.
3. Attach ALC-DT-BT-WH to electrical box with provided screws.
4. Install wall plate
5. Turn power ON to controlling circuit.
6. Once powered, a Green LED indicator light will start flash for 1 minute..

NOTES: For Programming instructions please visit www.Intermatic.com. The Arista App is available on Apple App and Google Play stores. (Search for Arista by Intermatic)

Bluetooth Operations have a maximum range of 100'.

WIRING DIAGRAM

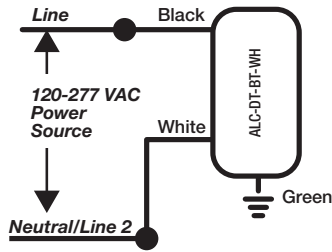

Wire	Description
White	Connects to Neutral/Line 2 from Power Source
Black	Connects to Line from Power Source
Green	Connects to ground

NOTE: To be installed in single- or double-gang applications with 2-1/2" minimum depth. Please consult a qualified electrician for specific wiring details.

SWITCH INTERFACE

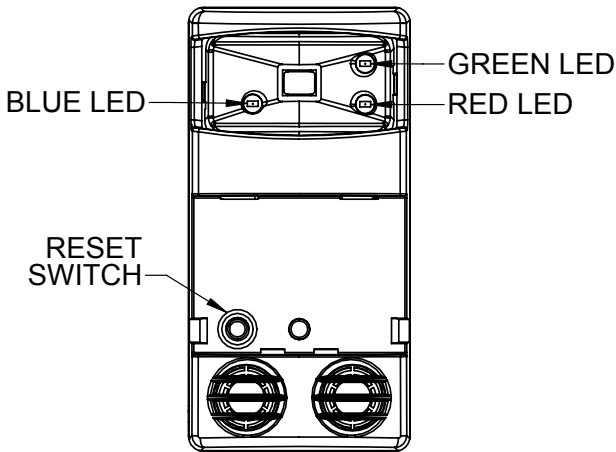

SHOWN WITHOUT COVER AND LENSE

COVERAGE AREA

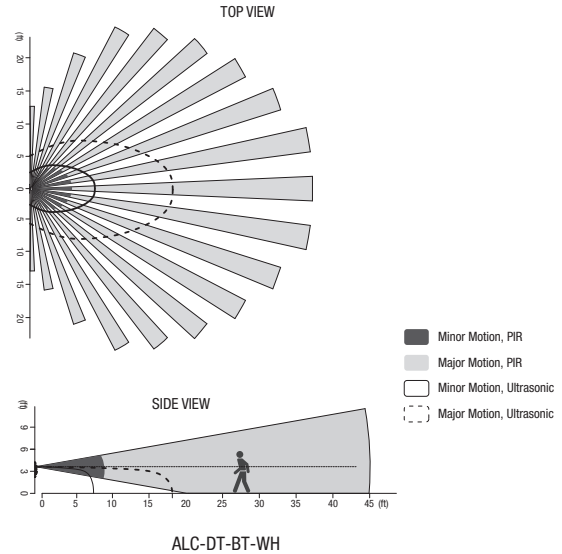

TROUBLESHOOTING

Symptom	Solution
During installation, the ARISTA Mobile App can't find the sensor when scanning for devices in the area	<ul style="list-style-type: none"> Verify power is supplied to the sensor. Make sure the Blue LED is blinking slowly. If not, the sensor could already be provisioned into another area. If this is correct, factory reset the device by pressing the reset button for more than 10 seconds. Make sure you are within range of the sensor. Verify Bluetooth Radio of programming device is turned ON
Sensor is energizing the lights without motion being detected in the space	<ul style="list-style-type: none"> Verify zone configuration using the ARISTA Mobile App is correct. Sensitivity may be set too high. Using the ARISTA Mobile App, lower the sensors sensitivity setting.
Sensor doesn't detect motion when person enters the space	<ul style="list-style-type: none"> Verify power is supplied to the sensor. If Blue LED is blinking slow, the sensor hasn't been provisioned into the zone using the ARISTA Mobile App and will not operate properly. Verify the sensor is detecting motion by walking by the sensor and verifying the Green LED blinks briefly. Sensitivity setting may be set too low. Using the ARISTA Mobile App, increase the sensors sensitivity setting. Verify sensor configuration (i.e. – time delay). Make certain zone configuration is set to Occupancy and not Vacancy. Change mounting location.
Sensor's Red LED is on solid	<ul style="list-style-type: none"> Replace Sensor
Sensor is de-energizing the lights while still in the space	<ul style="list-style-type: none"> Sensitivity setting may be set too low. Using the ARISTA Mobile App, increase the sensors sensitivity setting. Change mounting location.
Sensor leaves the lights energized after having left the space	<ul style="list-style-type: none"> Verify sensor configuration (i.e. – time delay).

LIMITED WARRANTY

This warranty service is available by either (a) returning the product to the dealer from whom the unit was purchased or (b) completing a warranty claim online at www.intermatic.com. This warranty is made by: Intermatic Incorporated, Customer Service, 1950 Innovation Way Suite 300, Libertyville, IL 60048. For warranty service go to: www.intermatic.com or call 815-675-7000.

For complete information on Intermatic products, literature and Contractors Guides visit www.intermatic.com.