



ALC-2B-BT



ALC-4B-BT

COMPLIANCE

This device complies with part 15 of the FCC. Operation is subject to the following two conditions: (1) this device may not cause harmful interference, and (2) this device must accept any interference received, including interference that may cause undesired operation.

FCC NOTE: The manufacturer is not responsible for any radio or TV interference caused by unauthorized modifications to this equipment. Such modifications could void the user's authority to operate the equipment.

NOTE: This equipment has been tested and found to comply with the limits for a Class B digital device, pursuant to Part 15 of the FCC Rules. These limits are designed to provide reasonable protection against harmful interference in a residential installation. This equipment generates, uses and can radiate radio frequency energy and, if not installed and used in accordance with the instructions may cause harmful interference to radio communications. However, there is no guarantee that interference will not occur in a particular installation. If this equipment does cause harmful interference to radio or television reception, which can be determined by turning the equipment off and on, the user is encouraged to try to correct the interference by one or more of the following measures:

- Reorient or relocate the receiving antenna
- Increase the separation between the equipment and receiver
- Connect the equipment into an outlet on a circuit different from that to which the receiver is connected
- Consult the dealer or an experienced radio/TV technician for help

Important note: To comply with the FCC RF exposure compliance requirements, no change to the antenna or the device is permitted. Any change to the antenna or the device could result in the device exceeding the RF exposure requirements and void user's authority to operate the device.

This Class B digital apparatus complies with ICES-005 of Canada.

RATINGS¹

Operating Voltage: DC Power 24VDC, 2mA / Battery Power 3VDC (CR2032)

Operating Temperature: 0° - 55° C (32° - 131° F)

Dimensions: 66.5mm H x 33mm W x 11mm D
(Not including mounting plate)

Wiring Terminals are suited for 16-22 AWG wire with a maximum length of 200 ft. 18 AWG solid wire is recommended.

Type 1 Action, Operating Control, PD2 Pollution Degree, Impulse voltage 330V



ALC-2B-BT ALC-4B-BT

Programmable Switches

WARNINGS/SAFETY

⚠ WARNING

RISK OF FIRE OR ELECTRIC SHOCK

- Turn OFF power at circuit breaker or fuse and test that the power is OFF before wiring.
- To be installed and/or used in accordance with appropriate electrical codes and regulations.
- If you are not sure about any part of these instructions, consult a qualified electrician.
- Use this device only with copper or copper clad wire.
- INDOOR USE ONLY

⚠ WARNING

- **Ingestion Warning:** This product contains a button cell or coin battery.
- **DEATH** or serious injury can occur if ingested.
- A swallowed button cell or coin battery can cause **Internal Chemical Burns** in as little as **2 hours**.
- **KEEP** new and used batteries **OUT OF REACH OF CHILDREN**
- **Seek immediate medical attention** if a battery is suspected to be swallowed or inserted inside any part of the body.



NOTICE

- Dispose of product per local regulations on the disposal of lithium batteries.
- Remove and immediately recycle or dispose of used batteries according to local regulations and keep away from children. Do NOT dispose of batteries in household trash or incinerate.
- Even used batteries may cause severe injury or death.
- Replace only with CR2032 (3V) Battery.
- Call a local poison control center for treatment information.
- Non-rechargeable batteries are not to be recharged.
- Do not force discharge, recharge, disassemble, heat above (manufacturer's specified temperature rating) or incinerate. Doing so may result in injury due to venting, leakage or explosion resulting in chemical burns.
- Ensure the batteries are installed correctly according to polarity (+ and -)."
- Do not mix old and new batteries, different brands or types of batteries, such as alkaline, carbon-zinc, or rechargeable batteries.
- Remove and immediately recycle or dispose of batteries from equipment not used for an extended period of time according to local regulations.
- Always completely secure the battery compartment. If the battery compartment does not close securely, stop using the product, remove the batteries, and keep them away from children.

NOTE: To be used with Class 2 low voltage wiring and power supply.

PRODUCT OVERVIEW

The ALC-2B-BT / ALC-4B-BT multi-function switches are designed for use with the ARISTA® Lighting Controls System by Intermatic.

These switches allow for each button to be configured for multiple operations including single tap, double tap, and press and hold operations. These switches can be configured for scene control or ON/OFF with dimming capabilities.

INSTALLATION

1. Determine if the unit will be battery powered or powered via 24VDC.
2. Determine the base plate and power source that will be used for the application.
3. For 24VDC applications, connect the wires as shown in the diagram with 24VDC going to the + terminal and negative going to the - terminal.
4. Secure the base plate with the proper hardware for the application. (6-32 screws for electrical openings, screws or double sided tape for surface mount applications)
5. For hand held or surface mounted battery operated units, remove plastic strip that isolates battery, ensure the battery is properly installed and the cover is in place.

NOTES: For Programming instructions please visit www.Intermatic.com. The ARISTA App is available on Apple App and Google Play stores. (Search for ARISTA by Intermatic)

Bluetooth Operations have a maximum range of 100'.

Mounting location should be within 100 feet of the closest ARISTA device. Configuration using the Mobile App requires the user to be within 40 to 60 feet of the device.

WIRELESS REMOTE (CR 2032)

NOTICE: Do not press any buttons while replacing the battery to avoid any programming issues.

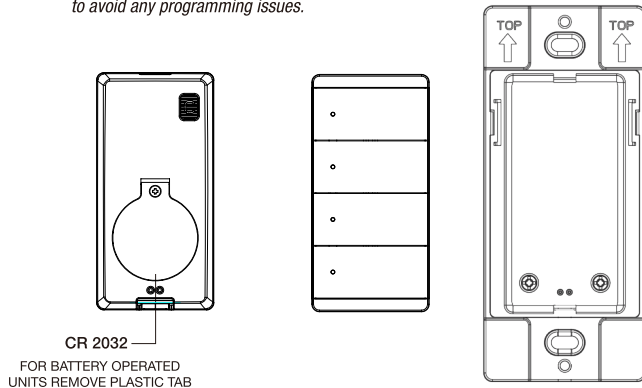

NOTICE: If the tab is pulled and the battery becomes active but the switch is powered by 24V - the device will behave as if it is powered by battery.

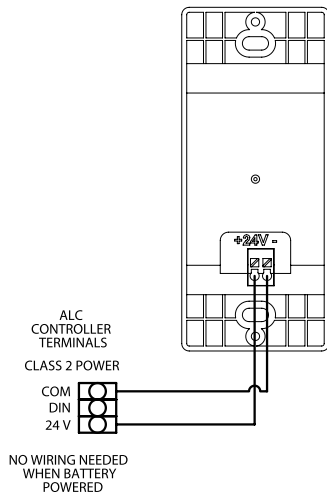

Wire from terminal on ARISTA controller	To terminal on ALC-2B-BT / ALC-4B-BT
24VDC (Class 2 Power)	+
COM (Common)	-
DI (Digital Input)	Not Used

NOTE: To be installed in a listed single or double-gang junction box with a 2-1/2" minimum depth. Please consult a qualified electrician for specific wiring details.

TROUBLESHOOTING

Symptom	Solution
During installation, the ARISTA Mobile App can't find the switch when scanning for devices in the area	<ul style="list-style-type: none"> Verify power is supplied or the battery is installed in the unit. Make sure the Blue LED is blinking slowly. If not, the sensor could already be provisioned into another area. If this is correct, press and hold top and bottom buttons until the red light illuminates on the top switch.
Button press is not activating controller	<ul style="list-style-type: none"> Verify that the switch has been provisioned and commissioned to the zone properly. Verify that the battery is installed or that 24 VDC is going to the switch.
Button press not activating any LED indicators or any ARISTA devices	<ul style="list-style-type: none"> Contact Intermatic Technical Support

LIMITED WARRANTY

This warranty service is available by either (a) returning the product to the dealer from whom the unit was purchased or (b) completing a warranty claim online at www.Intermatic.com. This warranty is made by: Intermatic Incorporated, Customer Service, 1950 Innovation Way, Suite 300, Libertyville, IL 60048. For warranty service go to: www.Intermatic.com or call 815-675-7000.

For complete information on Intermatic products, literature and Contractors Guides visit www.Intermatic.com.

DIMENSIONS

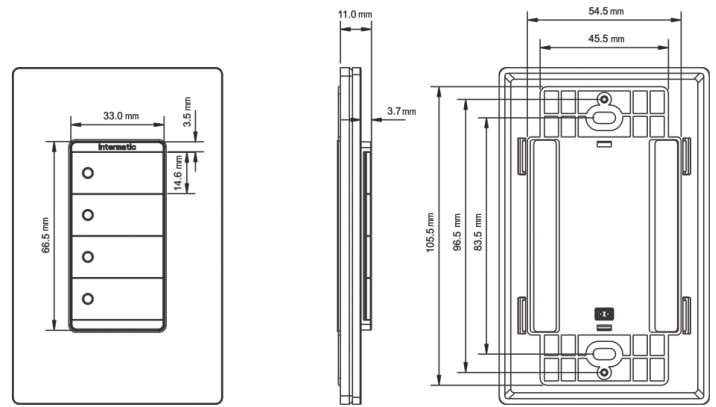

MOUNTING OPTIONS

