



ALC1-P

COMPLIANCE

This device complies with part 15 of the FCC. Operation is subject to the following two conditions: (1) this device may not cause harmful interference, and (2) this device must accept any interference received, including interference that may cause undesired operation.

FCC NOTE: The manufacturer is not responsible for any radio or TV interference caused by unauthorized modifications to this equipment. Such modifications could void the user's authority to operate the equipment.

NOTE: This equipment has been tested and found to comply with the limits for a Class B digital device, pursuant to Part 15 of the FCC Rules. These limits are designed to provide reasonable protection against harmful interference in a residential installation. This equipment generates, uses and can radiate radio frequency energy and, if not installed and used in accordance with the instructions may cause harmful interference to radio communications. However, there is no guarantee that interference will not occur in a particular installation. If this equipment does cause harmful interference to radio or television reception, which can be determined by turning the equipment off and on, the user is encouraged to try to correct the interference by one or more of the following measures:

- Reorient or relocate the receiving antenna.
- Increase the separation between the equipment and receiver.
- Connect the equipment into an outlet on a circuit different from that to which the receiver is connected.
- Consult the dealer or an experienced radio/TV technician for help.

Important note: To comply with the FCC RF exposure compliance requirements, no change to the antenna or the device is permitted. Any change to the antenna or the device could result in the device exceeding the RF exposure requirements and void user's authority to operate the device.

This Class B digital apparatus complies with ICES-005 of Canada.

WARNINGS/SAFETY

WARNING

Risk of Fire or Electric Shock

- Disconnect power at the circuit breaker(s) or disconnect switch(es) before installing or servicing.
- Installation and/or wiring must be in accordance with national and local electrical code requirements.
- Only use copper conductors rated 105° C minimum
- Battery is not user replaceable.
- Do NOT use timer to control devices that could have dangerous consequences due to inaccurate timing, such as sun lamps, saunas, heaters, and crock pots.
- Class 2 connections shall be torqued to 4.5 lb-in.

NOTICE

Dispose of product per local regulations on the disposal of lithium batteries.

Ratings¹

Operating Voltage	120-277 VAC, 50/60 Hz
Electronic Ballast/LED	5 A, 120-277 VAC, 50/60 Hz
Tungsten	5 A, 120-277 VAC, 50/60 Hz
MLV	450 VA, Minimum 5W, 120 VAC, 50/60 Hz
ELV	600W, 120 VAC, 50/60 Hz
Class 2	24 VDC, 135mA Total
Operating Temperature	0° to 55° C (32° to 131° F)
Dimensions	5.00" H x 4.21" W x 2.05" D (Including stem)

¹The ALC1-P is suitable for plenum use.

¹Type 1 action, operating control, PD2 pollution degree, Impulse voltage 4000V, Independantly mounted.

INSTALLATION

1. Turn off power to the controlling circuit.
2. Determine the electrical junction box that will be used for mounting. (Standard or Deep 4" junction box is recommended).
3. Determine the proper 1/2" knockout to be used.
4. Remove the knockout from the electrical box.
5. Insert nipple with wire leads through the knockout opening.
6. Use provided locknut to secure the ALC1-P to the electrical box.
7. Tighten locknut accordingly to make sure ALC1-P is secured.
8. Connect wiring following the wiring diagrams provided below.
9. Turn power ON to the controlling circuit.
10. Verify the Green LED indicator activates and deactivates upon press of the Power button.

Notes: For programming instructions please visit www.intermatic.com. The ARISTA® App is available on The App and Google Play stores. (Search for ARISTA by Intermatic)

Bluetooth® wireless operations have a maximum range of 100'

This device communicates with other devices and should not be installed in a metal enclosure.

ALC1-P CLASS 1 WIRING DIAGRAM

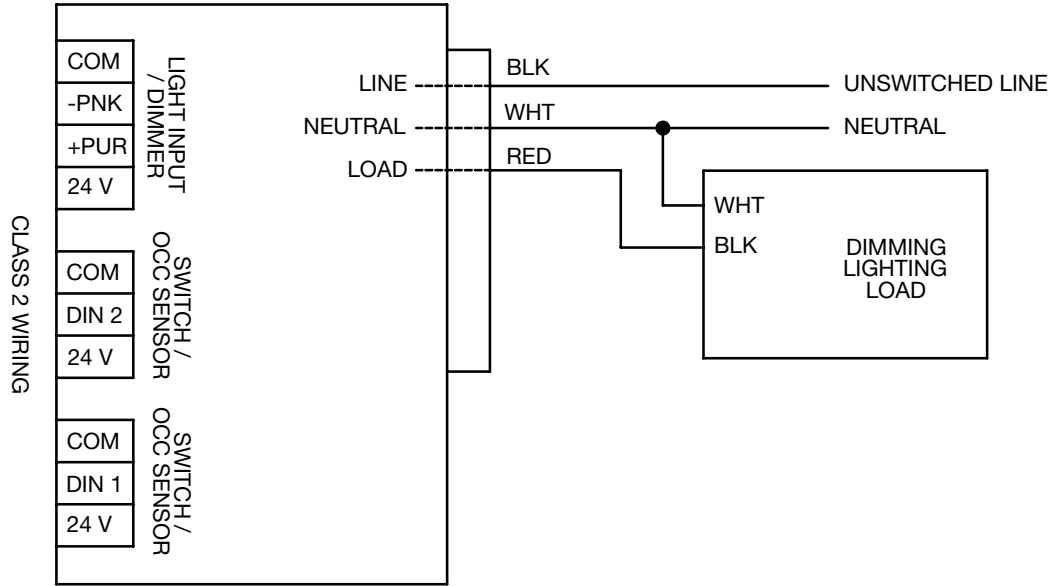

Wire	Description
Red	Connects to black wire from load
White	Connects to white (neutral) wire from load and power source
Black	Connects to black (hot) wire from power source

ALC1-P DIGITAL INPUT WIRING DIAGRAM

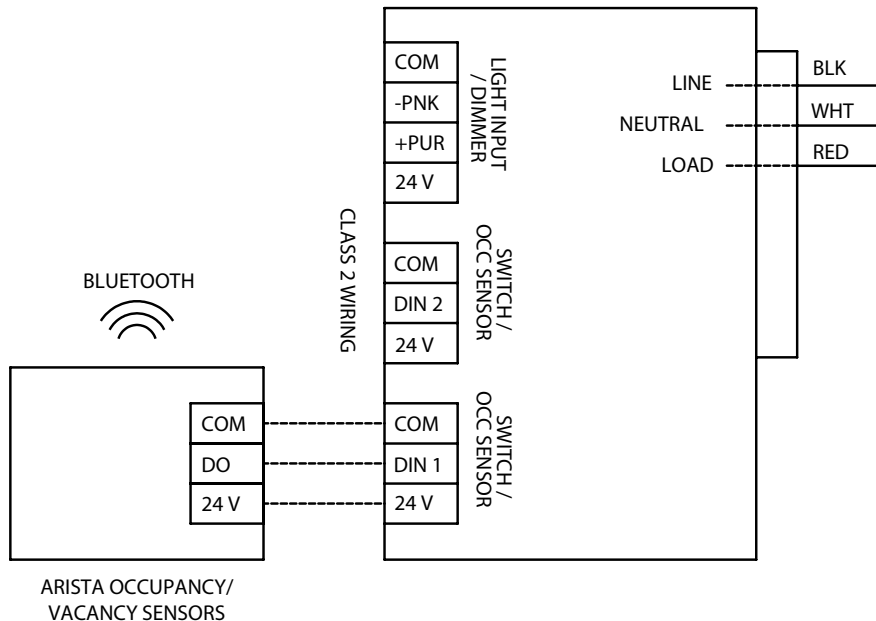

Note: Communications can be done through the Bluetooth® mesh network or be wired when using 24 VDC.

Terminal	Description
COM	Connect to COM (Common) from switch/sensor
DIN1 or DIN2	Connect to DO (Digital Output) from switch/sensor
24 V	Connect to 24 V (Power) from switch/sensor

Note: Maximum distance <= 200' with a minimum wire size of 24 AWG; maximum wire size of 16 AWG.

ALC1-P ANALOG INPUT WIRING DIAGRAM

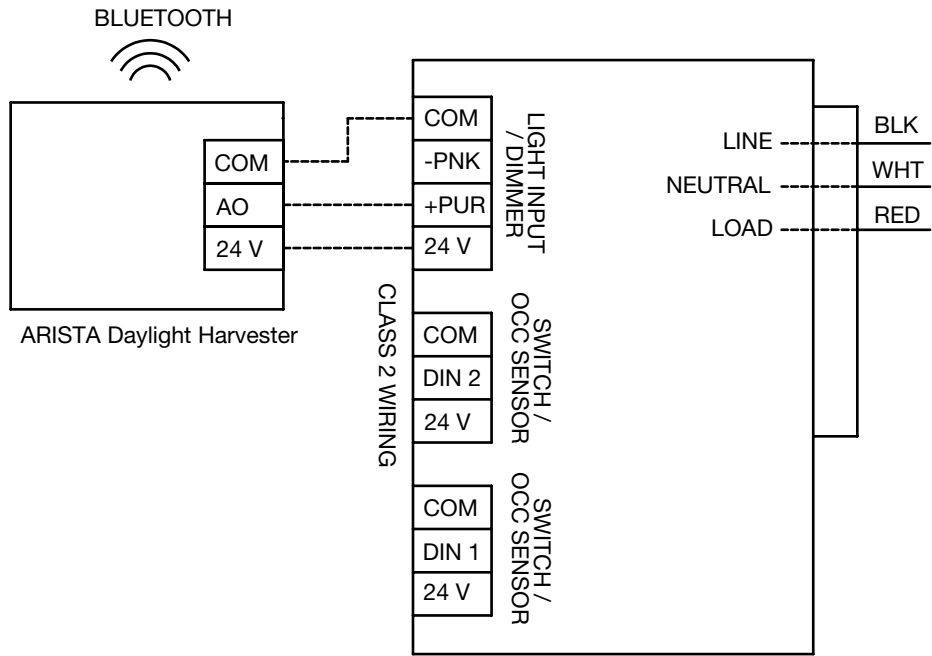

Terminal	Description
COM	Connect to COM (Common) from sensor
-PNK	Connect to Pink 0-10 V analog output wire from sensor (Not needed when using ARISTA ALC-DH-BT Daylight Harvester)
+PUR	Connect to AO (Analog Output) from sensor
24 V	Connect to 24 V (Power Input) for sensor

Note: 1. Maximum wiring distance $\leq 200'$ with a minimum size of 24 AWG; maximum size of 16 AWG.
 2. Communications can be done via Bluetooth® mesh network or wired when using 24 V installations and ARISTA ALC-DH-BT Daylight Harvesters.

ALC1-P 3RD PARTY 0-10 V DIMMER WIRING DIAGRAM

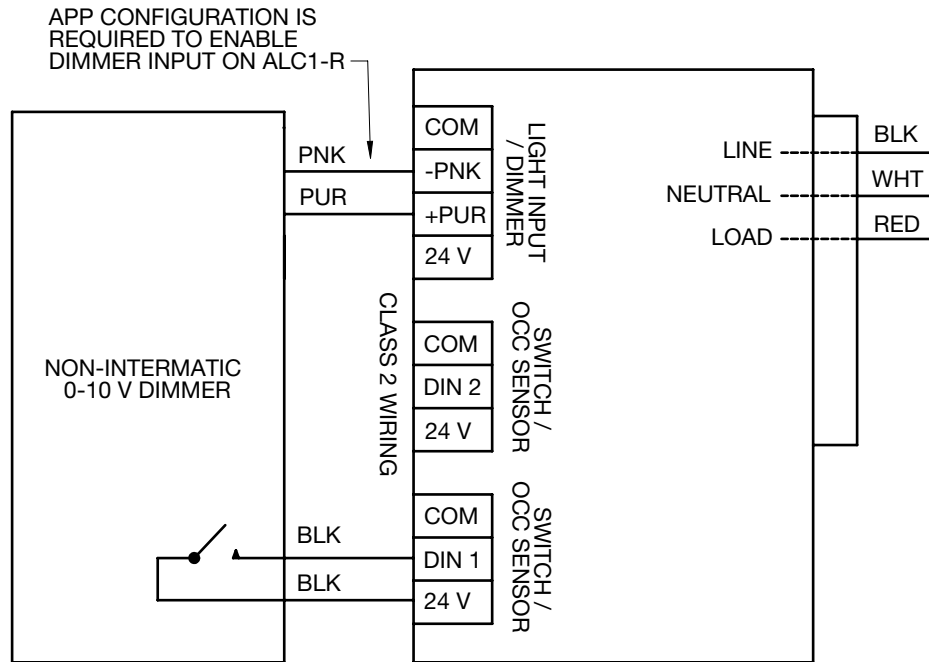

Terminal	Description
-PNK	Connect to Pink 0-10 V wire from dimmer
+PUR	Connect to Purple 0-10 V wire from dimmer
DIN1 or DIN2	Connect switch leg side of dimmer (App configuration required for DIN2)
24 V	Connect to power side of dimmer

- Note:**
1. This approach utilizes both digital and analog inputs on the ALC1-P.
 2. When using a non-Intermatic dimmer switch, daylight harvesting will need to be installed as a wireless configuration.
 3. Additional configurations may be required in the app depending on switching configurations.

All inductive loads require the ALC1-P to be used in Leading Edge Mode of operation to ensure product life expectancy.

WARRANTY

This warranty service is available by either (a) returning the product to the dealer from whom the unit was purchased or (b) completing a warranty claim online at www.Intermatic.com.

This warranty is made by: Intermatic Incorporated, Customer Service, 1950 Innovation Way Suite 300, Libertyville, IL 60048.

For warranty service go to: www.Intermatic.com or call 815-675-7000.

For complete information on Intermatic products, literature and contractors guides visit www.Intermatic.com.